

system components

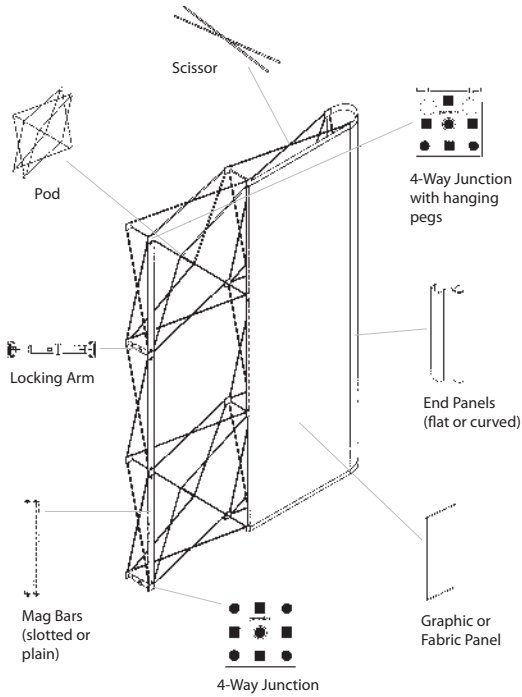

frame erection set-up

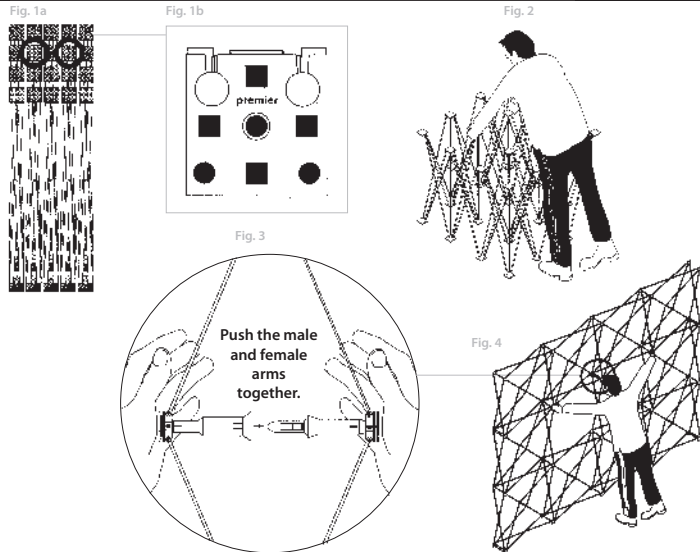

- Fig. 1a You should set-up the frame by holding the 4-Way junctions circled here.
- Fig. 1b Ensure the hanging pegs are at the top of the frame before you open it out and make sure the lighter grey 4-Way junctions are at the bottom.
- Fig. 2 When opening the frame, hold the 4-Way junctions as described in 1a and gently swing the frame from below you, out and up in front of you.
- Fig. 3 Once the frame is opened up, the next step is to make it stable. This is achieved by connecting the green locking arms, starting with the middle one. This one is used because it holds the frame most effectively. Once this is in place begin connecting the other locking bars.
- Fig. 4 Your frame is now fully open!

mag bar - connection

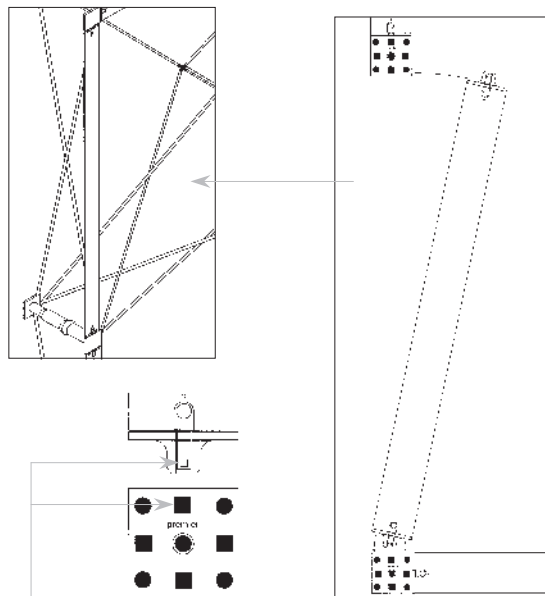

IMPORTANT
Connection is achieved when the two points indicated above come together. As you push the mag bar into the 4-Way junction, you will hear a click, which indicates a secure connection.

mag bar - disconnection

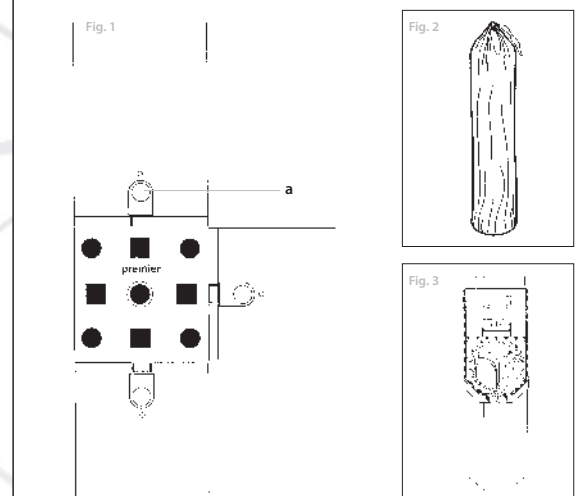

- Fig. 1 Press where indicated at point a and pull the mag bar away to disconnect from the 4-Way junction.
- Fig. 2 After the mag bars have been disconnected they should be placed carefully into their bag.
- Fig. 3 Place into the travel case.

set-up instructions